

Rev.	Creazione	Descrizione Modifica		Disegnatore
B	22/06/2020	Aggiornato		Musardo G.

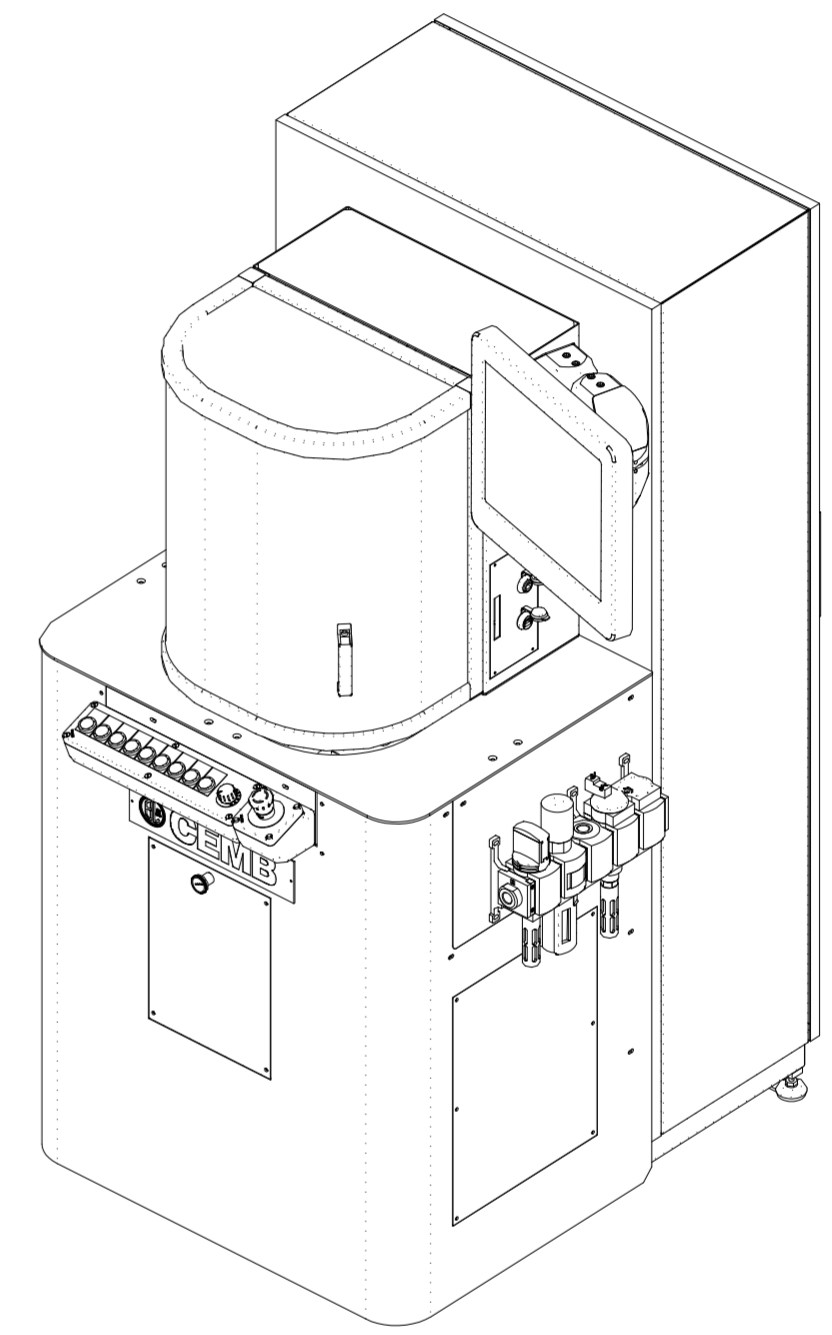

Gen2
Scala 1:12

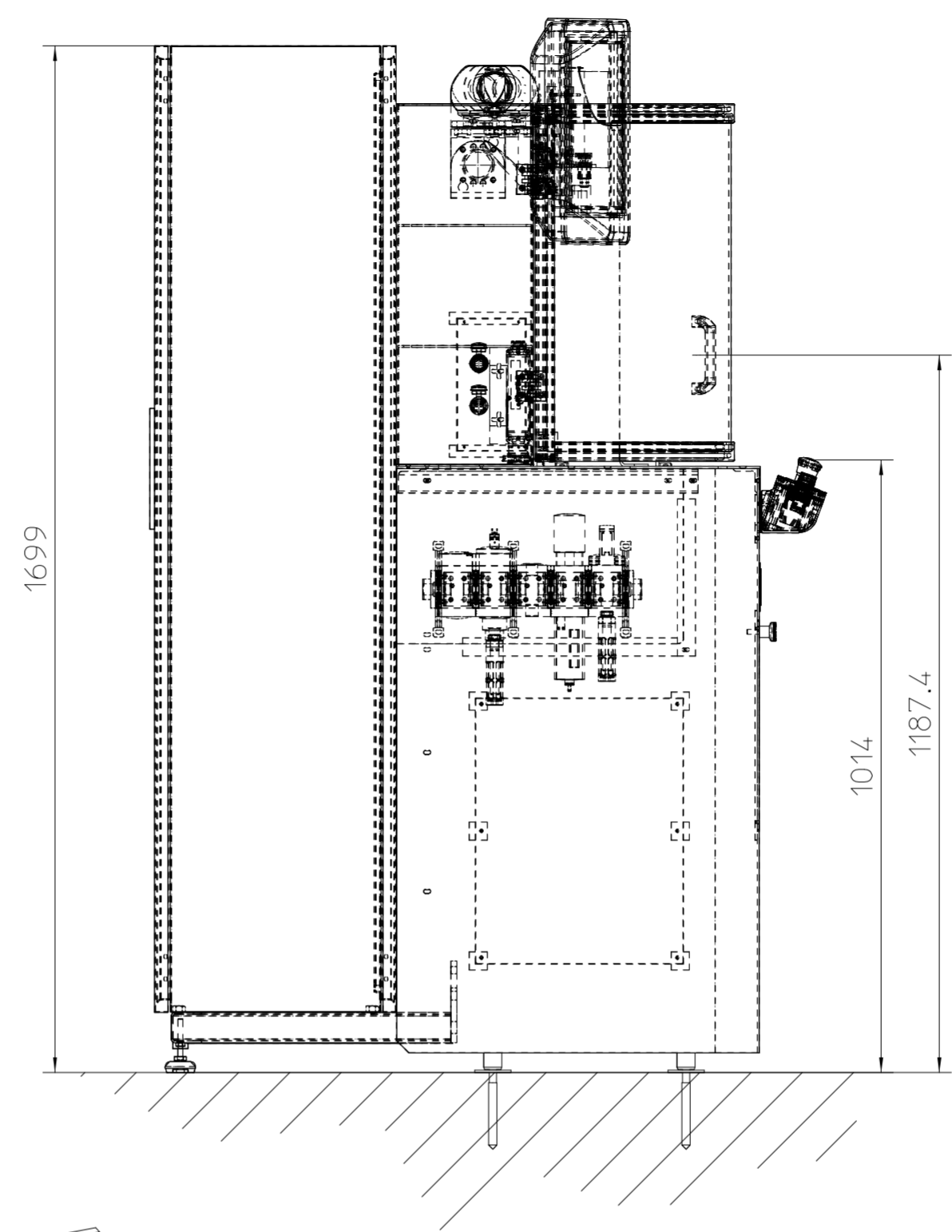
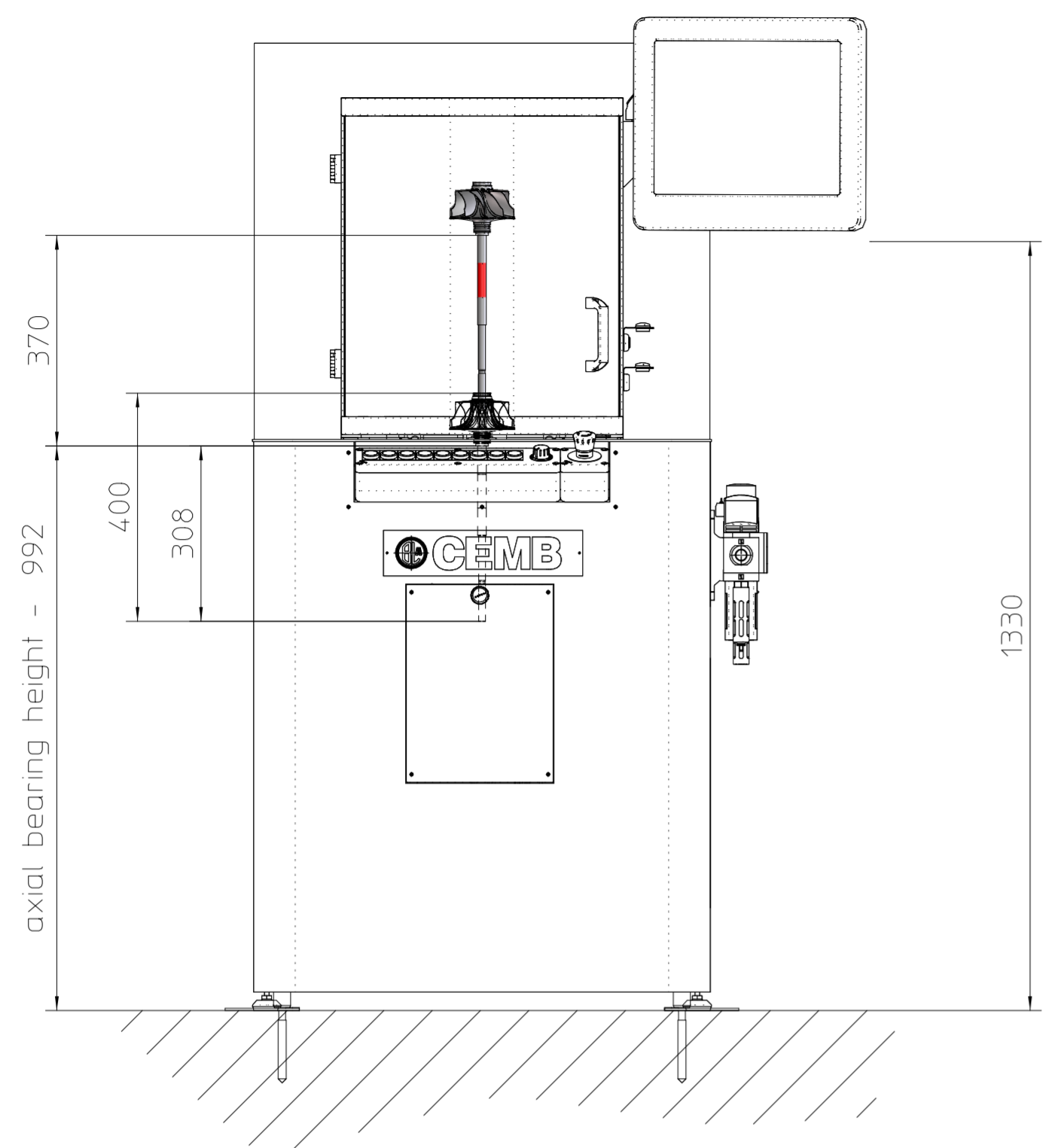
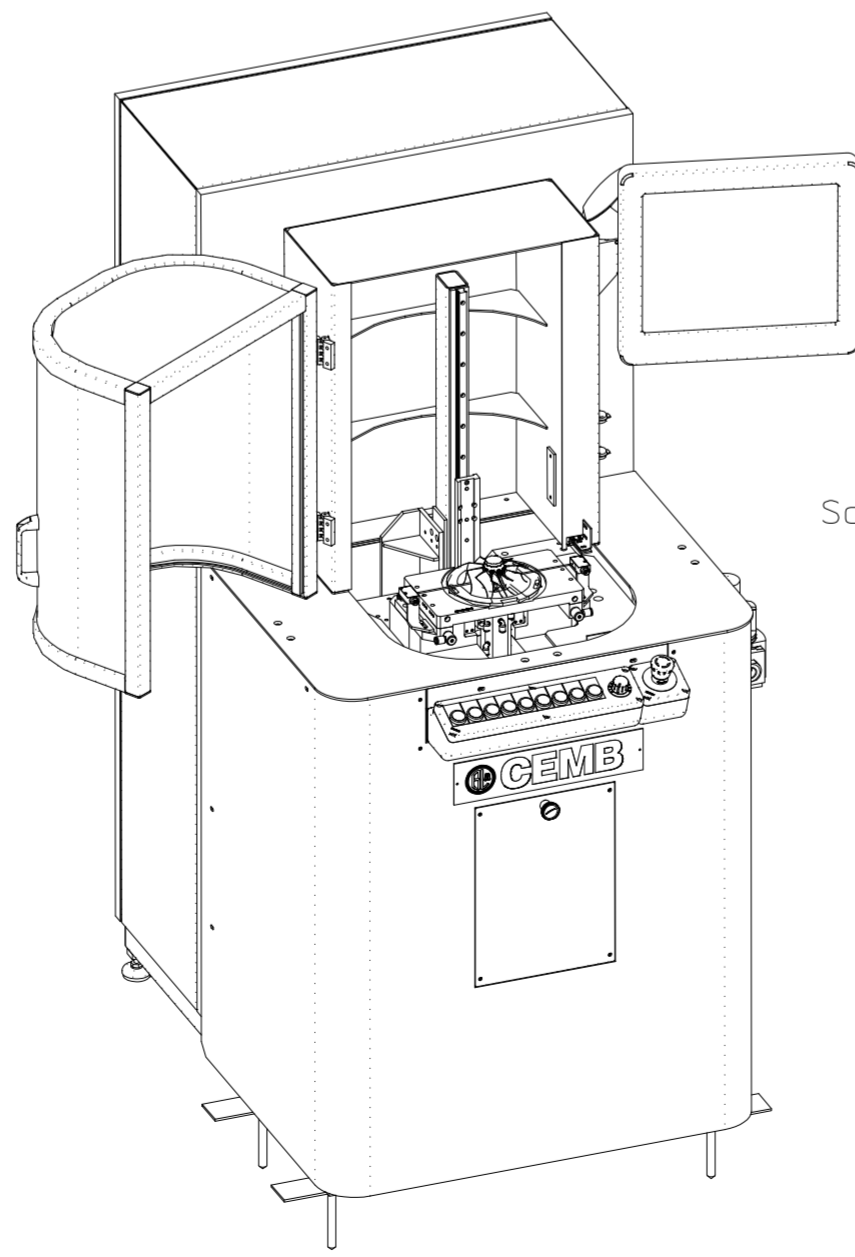
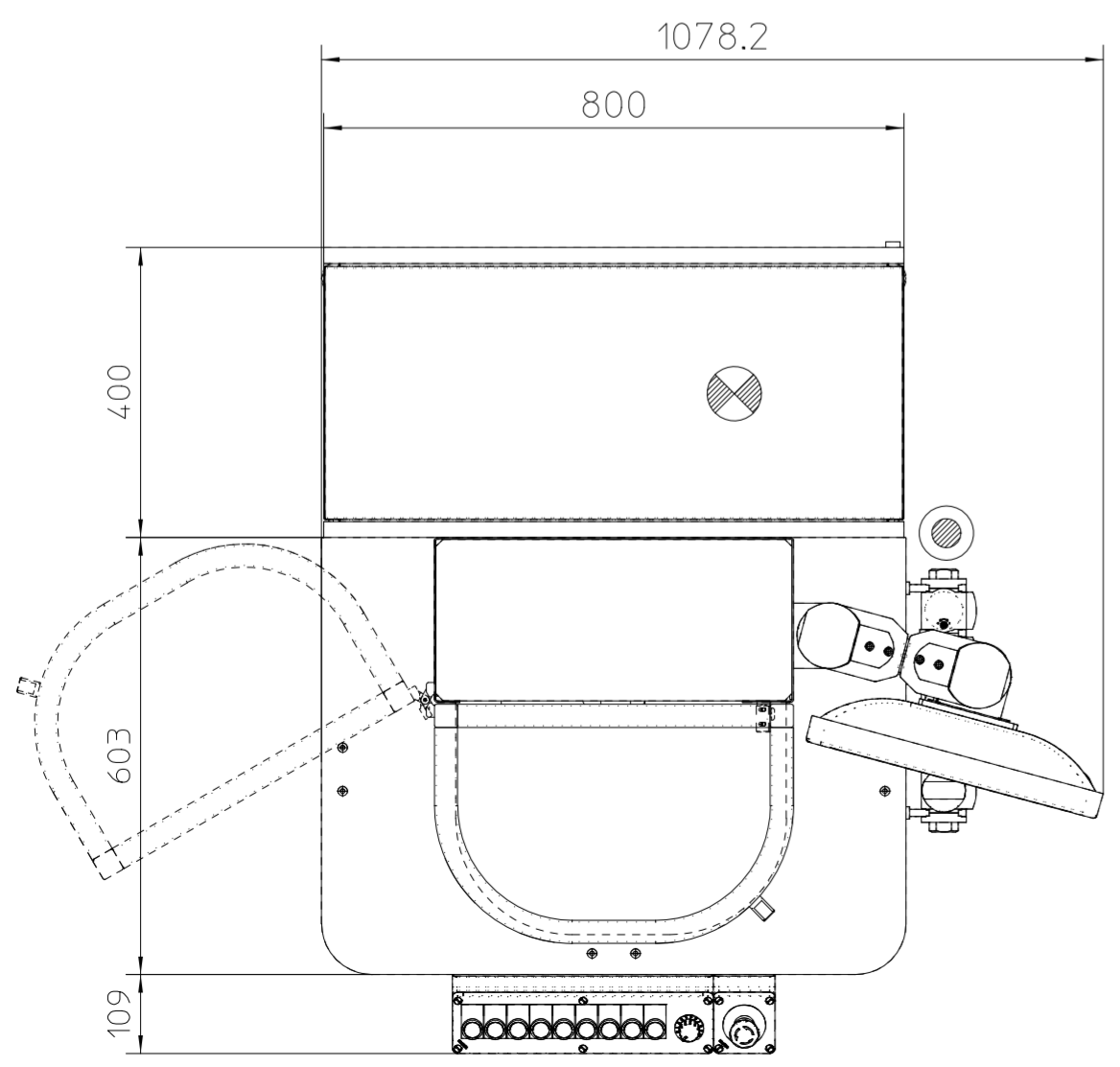

Gen1
Scala 1:13

- Power Supply
- Air Supply

A2	Ra 3.2	ELIMINARE SPIGOLI VIVI	TOLLERANZE ISO 2768-FH					CLIENTE : BORG WARNER - 312418
		RAGGI NON QUOTATI: 1 MAX	DA	0.5	7	31	121	
-	±0.05	SMUSSI NON QUOTATI: 0.5x45°	A	6	30	120	400	2000
		TOLLERANZE ANGOLARI: ± 30'	TOLL.	+0.05	+0.1	+0.15	+0.2	+0.5
NOTE			SCALA	1:10				MACCHINA : TCC/M-CV
DISEGNATORE	Musardo G.		FOGLIO	1 di 1				GRUPPO : Assieme Macchina TCC/M-CV
DATA	10/06/2020							
RICAVATO DA			PESO					
TRATT. SUP.			DUREZZA					CODICE GRUPPO : 47VM039611
TRATT. TERM.			PROFONDITA'					DENOMINAZIONE :
MARCATURA			REPORT MISURA					Layout TCC/M-CV



CEMB
Costruzioni Elettro Meccaniche
Ing. Buzzi & C. - S.p.A.

DIS. N. 39IV040323

REV. B