

# DWA 1100 TRUCK

## 8-CCD SENSOR TRUCK ALIGNMENT SYSTEM



# DWA 1100 TRUCK

**UK LITHIUM BATTERIES:** 24 hours of work, 1 year guaranteed  
**FEATHERWEIGHT SENSORS:** only 2.8 kg  
 Immediate connection with innovative **BT<sup>2</sup> wireless communication**  
**SILICON ACCELEROMETER:** shock-proof  
**SUNLIGHT FILTER:** over 12 m wheelbase even in outdoor sun exposed environment  
 Simple and **user-friendly software**

**IT BATTERIE AL LITIO:** 24 ore di lavoro, garanzia 1 anno  
**RILEVATORI PESO PIUMA:** solo 2.8 kg  
 Connessione immediata con l'innovativa **comunicazione senza fili BT<sup>2</sup>**  
**ACCELEROMETRO IN SILICIO:** insensibile agli urti  
**FILTRO SOLARE:** passo oltre 12 m anche in ambienti aperti e soleggiati  
**Software semplice e intuitivo**

**FR BATTERIES AU LITHIUM:** 24 heures de travail, garantie 1 an  
**DÉTECTEURS ULTRA LÉGERS:** 2.8 kg seulement  
**Connexion avancée immédiate sans fils BT<sup>2</sup>**  
**ACCÉLÉROMÈTRE EN SILICIUM:** insensible aux chocs  
**FILTRE DE SOLEIL:** empattement de plus de 12 m y compris à ciel ouvert  
 et en présence de soleil  
**Logiciel simple et intuitif**

**DE BESONDERS LANGE LEBENSDAUER:** 24 Arbeitsstunden, 1 Jahr Garantie  
**FEDERLEICHTE MESSKÖPFE:** nur 2.8 kg Gewicht  
 Übertragung der Messdaten ohne Kabel mit **BT<sup>2</sup> sofortige Verbindung**  
**BESCHLEUNIGUNGSMESSER AUS SILICIUM:** schlagfest  
**SONNENLICHTFILTER:** keine verlängerungen mehr nötig Achsabstand  
 über 12 m, auch im Freien und bei Sonneneinwirkung  
 Einfache und **intuitive Software**

**ES BATERÍAS DE LITIO:** 24 horas de trabajo, garantía 1 año  
**CAPTADORES PESOS PLUMA:** sólo 2.8 kg  
 Conexión inmediata con la innovadora **comunicación inalámbrica BT<sup>2</sup>**  
**ACELERÓMETRO EN SILICIO:** insensible a los golpes  
**FILTRO SOLAR:** paso superior a 12 m también en ambientes abiertos y asoleados  
**Software sencillo y fácil de usar**



## SOFTWARE

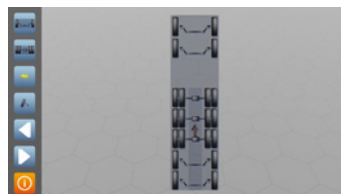

**UK Adjust two axles in one screen**  
**IT Regolazione di entrambi gli assi in un'unica schermata**  
**FR Réglage des deux essieux sur une unique page**  
**DE Einstellung beider Achse in einem einzigen Bildschirm**  
**ES Ajuste de ambos los ejes en una única pantalla**

**UK Step by step procedure up to 7 axles**  
**IT Procedura guidata fino a 7 assi**  
**FR Procédure pas à pas jusqu'à 7 essieux**  
**DE Schritt für Schritt-Verfahren bis zu 7 Achsen**  
**ES Procedimiento pilotado hasta 7 ejes**

**UK 2 measuring heads mode Quick measurement of front axle**  
**IT Modalità a due sensori Misurazione rapida dell'asse anteriore**  
**FR Mode deux capteurs Mesure rapide de l'essieu avant**  
**DE Zwei-Sensoren Modus Schnelle Messung der Vorderachse**  
**ES Modalidad 2 sensores Medición rápida del eje anterior**

**UK AUDIT function for the identification of driving problems**  
**IT Funzione AUDIT per la diagnosi completa dei disturbi di guida**  
**FR Fonction AUDIT pour l'identification des problèmes de conduite**  
**DE Funktion AUDIT für die Diagnose der Fahrstörungen**  
**ES Función AUDIT para la identificación de problemas de conducción**

## VERSIONS

### DWA1100<sup>TRUCK</sup> (with cabinet)

- 🇬🇧 **Ergonomic design**  
**Industrial computer**  
**No moving parts more likely to break**  
**Data update through USB**
- 🇮🇹 Design ergonomico  
 Computer industriale  
 Senza parti in movimento più soggette a rotture  
 Aggiornamento dati via USB
- 🇫🇷 Forme ergonomique  
 Ordinateur industriel  
 Sans disque en mouvement qui risquent davantage les ruptures  
 Mise à jour des données via USB
- 🇩🇪 Ergonomisches Design  
 Industrieller Computer  
 Ohne bewegliche Scheiben, dem stärkeren Bruch ausgesetzt sind  
 Daten-Update via USB
- 🇪🇸 Diseño ergonómico  
 Ordenador industrial  
 Sin partes en movimiento con más probabilidad de romperse  
 Actualización datos por medio de USB

### DWA1100<sup>TRUCK</sup> Light

- 🇬🇧 **No CABINET!** Save your working space with your laptop!
- 🇮🇹 **Senza ARMADIO!** Risparmi spazio di lavoro ed usi il tuo pc!
- 🇫🇷 **Sans ARMOIRE!** Gains d'espace de travail et utilisation de son propre PC!
- 🇩🇪 **Ohne STEUERSCHRANK!** Sie sparen Raum und benutzen Ihren eigenen PC!
- 🇪🇸 **¡Sin ARMARIO!** ¡Ahorras espacio de trabajo y utilizas tu PC!

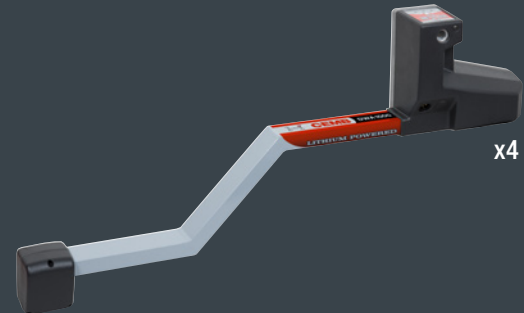

## STANDARD CONFIGURATION

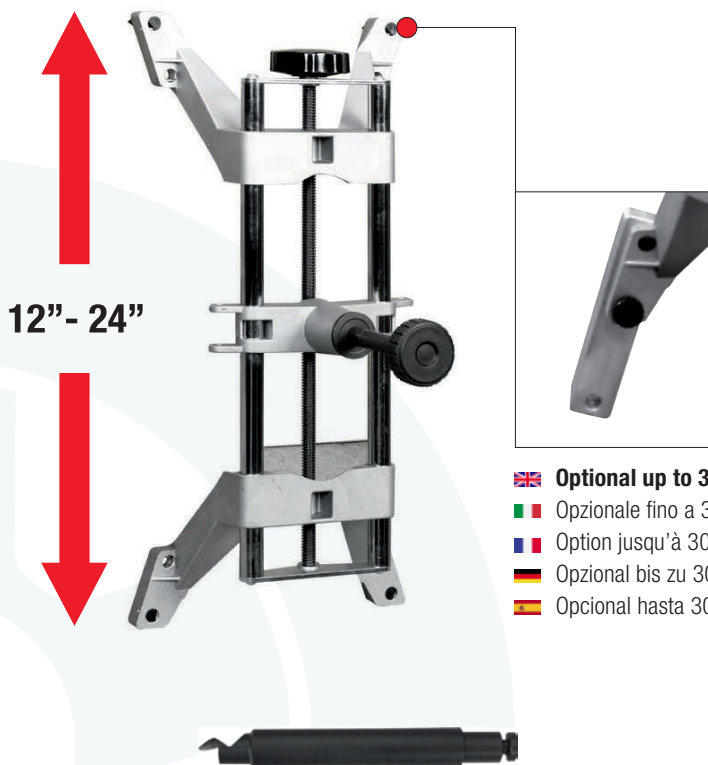

- 🇬🇧 **Optional up to 30"**
- 🇮🇹 Opzionale fino a 30"
- 🇫🇷 Option jusqu'à 30"
- 🇩🇪 Opzional bis zu 30"
- 🇪🇸 Opcional hasta 30"

### 🇬🇧 **Metal 120 mm universal grips, with reference surface, for truck and bus wheels**

- 🇮🇹 Unghiette universali 120 mm, con piano di riferimento, per ruote di autocarro e bus
- 🇫🇷 Onglets universels 120 mm en métal, avec surface de référence, pour roues de camion et de bus
- 🇩🇪 Universal-Radklammerfingern aus Metall 120 mm, mit Auflageoberfläche, für Räder von LKWs und Bussen
- 🇪🇸 Uñas universales 120 mm en metal, con superficie de referimiento, para ruedas de camión y bus

## OPTIONAL ACCESSORIES

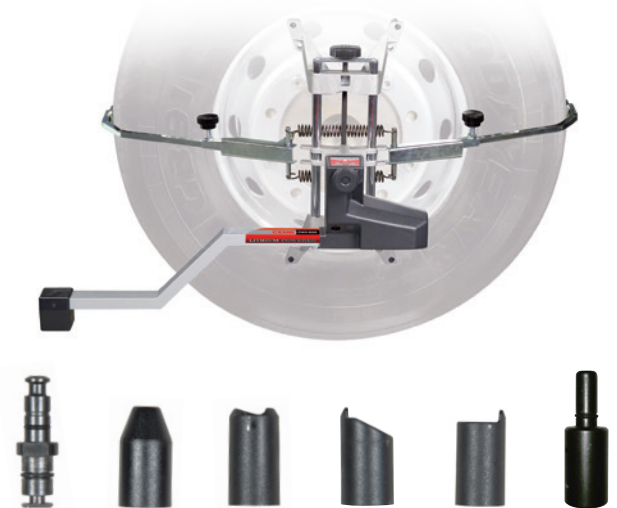

### 🇬🇧 **Clamp supporting arms and set of tips for tyres with external diameter up to 50"**

- 🇮🇹 Bracci e gruppo di puntali per aggrappo in appoggio a pneumatici con diametro esterno fino a 50"
- 🇫🇷 Bras et groupe de broches pour griffe en appui sur des pneus ayant un diamètre externe jusqu'à 50"
- 🇩🇪 Klemmarme und Positionsfinger für Radklammern zum Auflegen auf Reifen mit Aussendurchmesser bis zu 50"
- 🇪🇸 Brazos y grupo de puntales para mordaza en apoyo a neumáticos con diámetro externo hasta 50"

### **Grips for all rims and tyres are available**



- 🇬🇧 **Metal grips for clamping on steel rims from the inside**
- 🇮🇹 Unghiette in metallo per aggrappo dall'interno su cerchi in ferro
- 🇫🇷 Onglets en métal pour accrochage de l'intérieur sur jantes en fer
- 🇩🇪 Metallkrallen zum Halten von innen bei Eisenfelgen
- 🇪🇸 Uñas en metal para mordaza desde el interior en llantas en hierro

## STANDARD COMPOSITION

-  **Computer - 27" monitor - printer (only for DWA1100<sup>TRUCK</sup>)**  
Truck and bus software and database  
4 truck sensors  
4 clamps + safety elastic band + 1 set of grips  
Steering lock + Brake pedal lock
-  **Computer - monitor 27" - stampante (solo per DWA1100<sup>TRUCK</sup>)**  
Software e database per autocarro e bus  
4 rilevatori autocarro  
4 aggrappi + elastico di sicurezza + 1 set di unghiette  
Bloccasterzo + premipedale
-  **Ordinateur - moniteur 27" - imprimante (seulement pour DWA1100<sup>TRUCK</sup>)**  
Logiciel et base de données pour camions et autobus  
4 détecteurs camion  
4 griffes + élastique de sécurité + 1 jeux d'onglets  
Blocage direction + presseur pédale
-  **Industrieller PC, TFT-Bildschirm 27", Drucker (nur für DWA1100<sup>TRUCK</sup>)**  
Software und Datenbank für LKW und Bussen  
4 Messköpfe für LKW  
4 Radklammern + elastisches Schutzband + 1 Radklammerfinger  
1 Lenkradfeststeller, 1 Bremspedalfeststeller
-  **Ordenador - pantalla 27" - impresora (solo para DWA1100<sup>TRUCK</sup>)**  
Software y base de datos para camión y bus  
4 captadores camión  
4 mordazas + elástico de seguridad + 1 equipos de uñas  
Dispositivo antirrobo + apretapedal

## TECHNICAL DATA

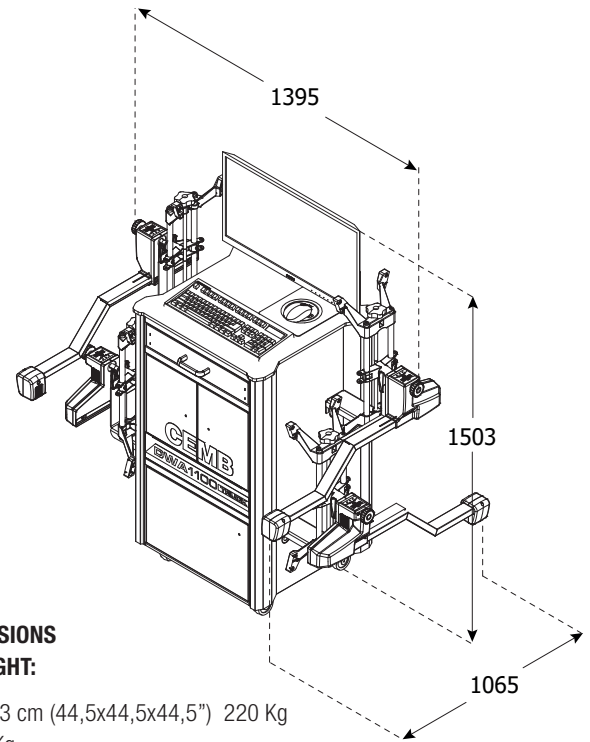





### PACKAGE DIMENSIONS AND GROSS WEIGHT:

TYPE: 113x113x113 cm (44,5x44,5x44,5") 220 Kg





**Net weight:** 155 Kg

## OPTIONS





-  **2 truck turnplates: capacity 4500 kg per plate, Ø 40 cm, with nylon spheres**
-  **2 piatti rotanti per autocarro: portata 4500 kg per piatto, Ø 40 cm, con sfere in nylon**
-  **2 plateaux rotatifs pour camion: portée 4500 kg par plateau, Ø 40 cm, avec sphères en nylon**
-  **2 Drehteller für LKW: Tragkraft 4500 kg pro Teller, Ø 40 cm, mit Nylonkugeln**
-  **2 platos de camiones: capacidad de 4500 kg por plato, Ø 40 cm, con esferas de nylon**







-  **2 ramps for truck turnplates**
-  **2 rampe per piatti rotanti autocarro**
-  **2 rampes pour plateaux rotatifs de camion**
-  **2 Rampen für Lkw-Drehteller**
-  **2 rampas para platos giratorios de camiones**



-  **Adaptor rod for semitrailers' king pin**
-  **Barra semirimorchio per perno ralla**
-  **Barre semi-remorque pour axe couronne**
-  **Sattelzug bar für Achsschenkelbolzen**
-  **Palanca semiremolque para perno rangua**



-  **WiFi connection for automatic software updates**
-  **Collegamento wifi per l'aggiornamento automatico del software**
-  **Connexion Wi-Fi pour la mise à jour du logiciel**
-  **Wifi-Verbindung zur automatischen Aktualisierung der Software**
-  **Conexión wifi para actualizar automáticamente el software**



# CEMB

BALANCING MACHINES

**CEMB S.p.A.**

Via Risorgimento, 9  
23826 Mandello del Lario (LC) - Italy

[www.cemb.com](http://www.cemb.com)



**Garage equipment division**  
**CEMB - ITALY**  
**Plant and Training Center**  
Phone +39 0341 706111  
[garage@cemb.com](mailto:garage@cemb.com)

**CEMB USA - BL Systems Inc.**  
2873 Ramsey Road  
Gainesville, GA 30501 - USA  
Phone +001 678 717 1050  
Fax +001 678 717 1056  
[sales@cemb-usa.com](mailto:sales@cemb-usa.com)